

**HORIZONTAL FLOW WORK STATION**

## **IAC INDUSTRIES**

3831 S BULLARD AVE., GOODYEAR, AZ 85338  
Phone (714) 990-8997 Fax (714) 990-0557  
[www.iacindustries.com](http://www.iacindustries.com)

## **HFS**

# **Operation and Maintenance Manual**

REV. (042318P65)

# TABLE OF CONTENTS OF TEXT INFORMATION

<u>TITLE</u>	<u>PAGE #</u>
General Description	2
Safety Precautions	3
Parts Identification / Overview	4-6
First Time Start Up Procedures	7
Air Flow Volume	8-9
Filter Maintenance & Replacement	10
Pre-filter Replacement	11
Lights	11
Airflow Volume Calibration	11
Particle Count Certification	11
General Information	11
Standard Operating Conditions	12
Work place and Equipment Controls	12

**IAC Industries recommends that all personnel responsible for the daily operation of any IAC Industries AirClean units read and understand this manual and follow it's recommended for use of AirClean units. This manual must stay with the unit at all times. Additional copies of this manual can be obtained from IAC Industries customer service personnel.**

## **GENERAL DESCRIPTION:**

All IAC AirClean Horizontal Flow equipment is built to the highest standards of quality and workmanship to meet and perform to the standards that are set forth in the IAC AirClean Operation Manual. IAC requires all customers read this and understand all the provisions in this manual prior to operation of the unit.

## **Customer Service Contact:**

If for any reason you experience a problem with you AirClean unit please contact IAC Industries' customer service at 1-800-989-1422 and ask for technical service for AirClean units.



Throughout this manual this marking indicates that if the instruction is not followed serious damage to the unit and/or personnel could occur. IAC Industries is not responsible for any injuries sustained or damage to the AirClean unit and its contents and/or damage to surrounding property caused by improper operation and/or maintenance of the AirClean Unit.

## Safety Precautions



### **WARNING:**

1. Never attempt to disassemble, repair, or modify the product while the unit is in operation and/or connected to the power source. If repairs are needed, the unit must be taken off line to avoid damage to the unit and/or personnel.
2. The Horizontal AirClean is designed to be powered by plugging it into a special outlet a minimum of 115 VAC with 20 AMP circuit protection. The running amperage draw for HFS AirClean units is less than 7 amps, however startup amperage requirements are higher.
3. Keep any water or other liquids from falling or splashing into or in any part of the AirClean housing.
4. Insert the power cord plug into a standard convenience outlet as far as it will go. Incomplete insertion may cause a fire due to electric shock or heat generation. Do not use damaged plugs.
5. Do not handle the power plug with a wet hand. An electric shock may occur.
6. Do not damage the power cord or power plug. If the power cord or plug is damaged due to modifications, bend it by force, twisting it, or bring it to close to any thermal device, electric shock, short circuit, or fire may occur.



### **CAUTION:**

1. Do not insert foreign objects such as pins or wires in the air intake grille, air outlet grille of the filters or gags.
2. When unplugging the power plug, grasp the power plug, not the power cord. Such handling may cause a short circuit or wire breakage, resulting in fire or electric shock.
3. Do not block the inlet airflow of the AirClean unit (pre-filter area), it may cause the AirClean to operation incorrectly and damage the AirClean housing assembly.



### **WARNING:**

**ALL PARTICLE BOARD USED IN IAC INDUSTRIES PRODUCTS ARE SOURCED ONLY FROM VENDORS THAT ARE CARB ATCM PHASE 2 AND TSCA TITLE VI COMPLIANT WITH VALID CERTIFICATES.** Drilling, Sawing, Sanding or Machining Wood products can expose you to wood dust, a substance known to the state of California to cause cancer. Avoid inhaling dust generated from wood products or use a dust mask to other safeguards for personal protection. This product can expose you to chemicals, including formaldehyde, which is known to the state of California to cause cancer, and methanol, which is known to the state of California to cause birth defects or other reproductive harm. For more information please visit, [www.P65WARNINGS.CA.GOV/WOOD](http://www.P65WARNINGS.CA.GOV/WOOD). COPY OF VENDOR CERTIFICATE AVAILABLE UPON REQUEST.

## Parts Identification / Overview

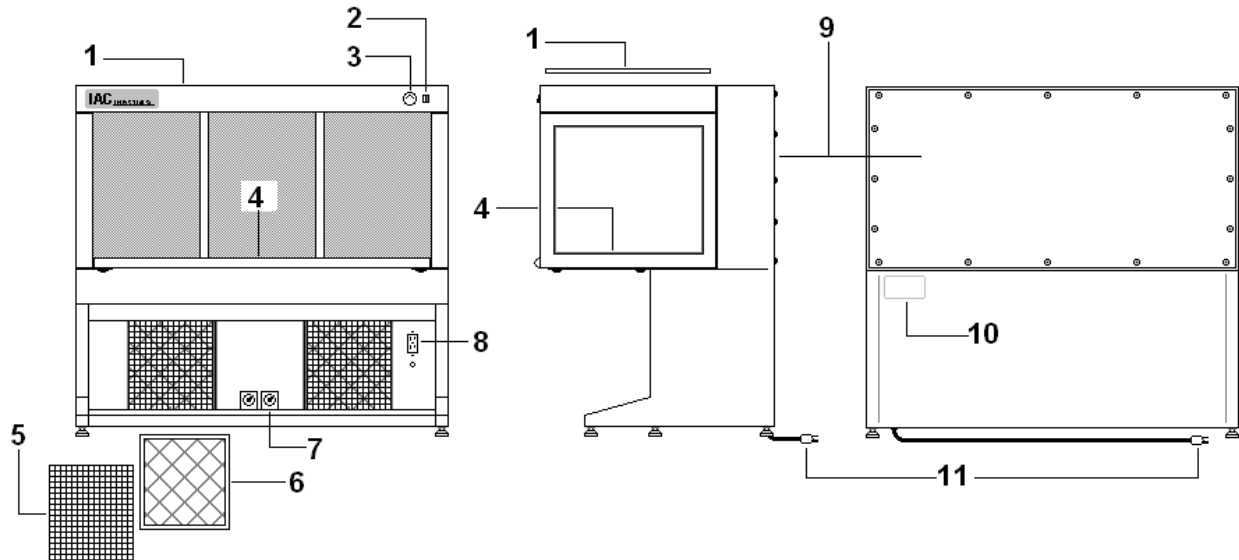

### **1 Light Cover**

This is the access cover that is used to install and protect the light tubes as well as a light reflector for maximum light candles to be reflected to the below work surface. It is important that this cover remain in place for maximum light reflection to the work surface.

### **2 Power/Light Switch:**

This switch is used to supply power to both the Airclean unit (Housing) and the light assembly for your unit.

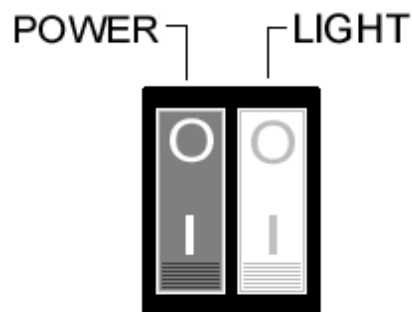

### 3 Minihelic Gage:

This gage is used to measure the air pressure inside the HFS housing and is helpful in determining when the HEPA filter may need to be replaced. (See page 10)

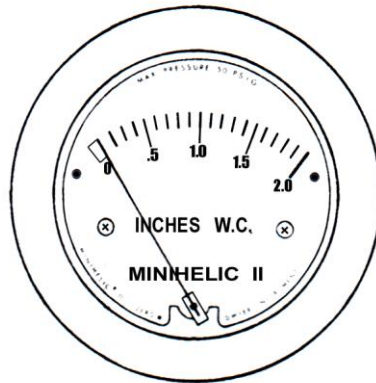

### 4 Worksurface:

Used for support items to be used in the airflow area.

### 5 Egg Crate Diffusers:

Used to protect the pre-filters and what goes into the inlet opening to the motor assembly.

### 6 Pre-filters:

Pre-filters are used to control the type of airflow into the motor assembly and any object from entering this area that could damage it. Abstains from placing anything in front of the pre-filter area that may block the airflow going into the motor assembly.

### 7 Motor speed controls:

Located inside the HFS housing below the work surface behind the egg crate diffusers, and pre-filters. Note: this speed control(s) have been set at the factory. Adjusting them will adjust the airflow volume.

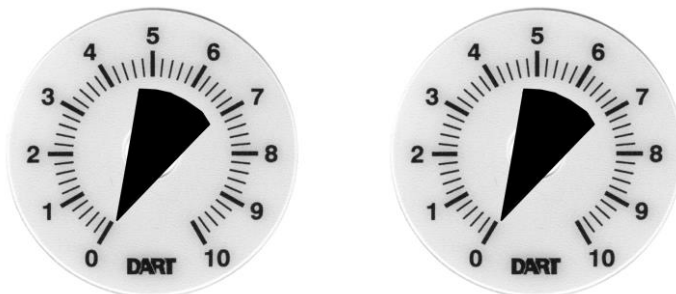

### 8 GFI Electrical Outlet: (If applicable)

This outlet provides a circuit protection AC power to be used for the AirClean unit. The electrical GFI supplies 115 VAC power with 20 AMP circuit protection.

## **Parts Identification / Overview cont .**

### **9 Back Panel:**

This panel allows access to the main filter and is recommended that at least two persons remove and / reinstall it.

### **10 Identification & Certification Label:**

This label contains identification information including Model number, serial number, RPM, Power Requirements, and Amps. All AirClean units are tested and certified at the factory to meet ISO-standard 14644-1 class 5 cleanroom specifications.

### **11 Power Cord:**

The power cord is used to supply the main power to your unit using an outlet that is setup for a minimum of 115 VAC with 20 AMP circuit protection.

## First Time Start-up Procedure:

All IAC Industries AirClean units are thoroughly inspected and tested to meet ISO-standard 14644-1 class 5 cleanroom specifications. The average airflow volumes are set as close to 100 CFM as possible at the time of testing. It is critical that these unit's are handled with care and that they are no exposed to extreme heat, cold or humidity. The unit must be installed by qualified installers and attached to the facilities house power supply by qualified personnel.

Electrical requirements: This unit requires 115VAC power on a 20 AMP minimum circuit. The running amperage draw is less than 7 amps however startup requires more amperage. Once the unit is connected to the power source properly proceed to the startup instructions below:

- A) Turn the unit's blower switch to "on" and allow the unit to run for 2 to 3 hours before conducting any certification testing. During this startup time it is a good idea to clean the inside surfaces of the unit per company cleanroom policies and procedures. If no cleaning procedures have been established cleaning the inside surfaces can be done using lint free wipes and isopropyl alcohol filtered to 0.5 microns.
- B) IAC calibrates each AirClean unit's airflow volume to an average of 100 CFM (cubic feet per minute) at the factory. Unless there have been changes made to the speed control of the unit it should perform at this level. If airflow volume certification tests are to be conducted before the unit is placed in service IAC recommends the use of a "vane" type monometer to conduct airflow volume testing. Thermal velocity "probe" type airflow testers are not recommended for these kinds of units and will not give accurate airflow volume measurements. Customers may adjust the airflow volume to their liking by following the instructions found on pages 8&9 of this manual. If the average airflow volume is less than 72 CFM IAC recommends it be adjusted up to average in the 90 CFM range, plus or minus 20%.
- C) When the airflow volume is adjusted to the customer's desired airflow volume and the unit has run continuously for 2 to 3 hours, particle count certification tests may be conducted.
- D) Maintaining best manufacturing practices with regard to clean room standards the unit is ready to use.
- E) This unit should not be turned off while it is in use. If it is shut down it needs to be cleaned and tested before it is put back into use.
- F) The unit's worksurface should be wiped down with a lint free cloth and approved cleaning solution every 8-hour shift or as is required by the customer's clean room specifications and procedures.

## **Airflow Volume:**

To maintain proper airflow volume it is important that adjustments be made to IAC AirClean units by qualified maintenance personnel trained in the proper measuring techniques for air clean units.

It is also recommended that measurement of airflow volume be made using a “vane” type anemometer with a minimum vane diameter of 2.5”. Thermal velocity probe type airflow testers are not recommended for measuring turbulent airflows.

The airflow volume is controlled by adjusting the solid-state speed controls which are connected to the impellers of the HFS AirClean unit. As the HEPA filter “loads up” with particles the airflow becomes more restricted reducing the volume of air exiting the filter. Adjusting the speed of the impellers will increase the airflow volume. The speed controls are located on the inside of the Air Clean housing unit below the worksurface as shown on page 9.

Note: **BEFORE** adjusting the airflow volume check the pre-filters and replace them if needed.

To access the speed controls and adjust the motor speed, follow the procedures below:

- 1) Remove the plastic egg-crate diffusers and the pre-filters as shown on the following page.
- 2) Locate the two speed control knobs, one on each side of the openings.
- 3) ALWAYS make very small adjustments to the speed controls. Turn the speed controls clockwise to increase the speed of the motor, turn them counter clockwise to decrease the speed of the motors.

Note: Each company using AirClean units should have it’s own policies and procedures for the proper operation, maintenance and calibration of the cleanroom equipment. The recommendations contained in this manual are based on the ISO standard 14644-1 and generally accepted clean room practices.



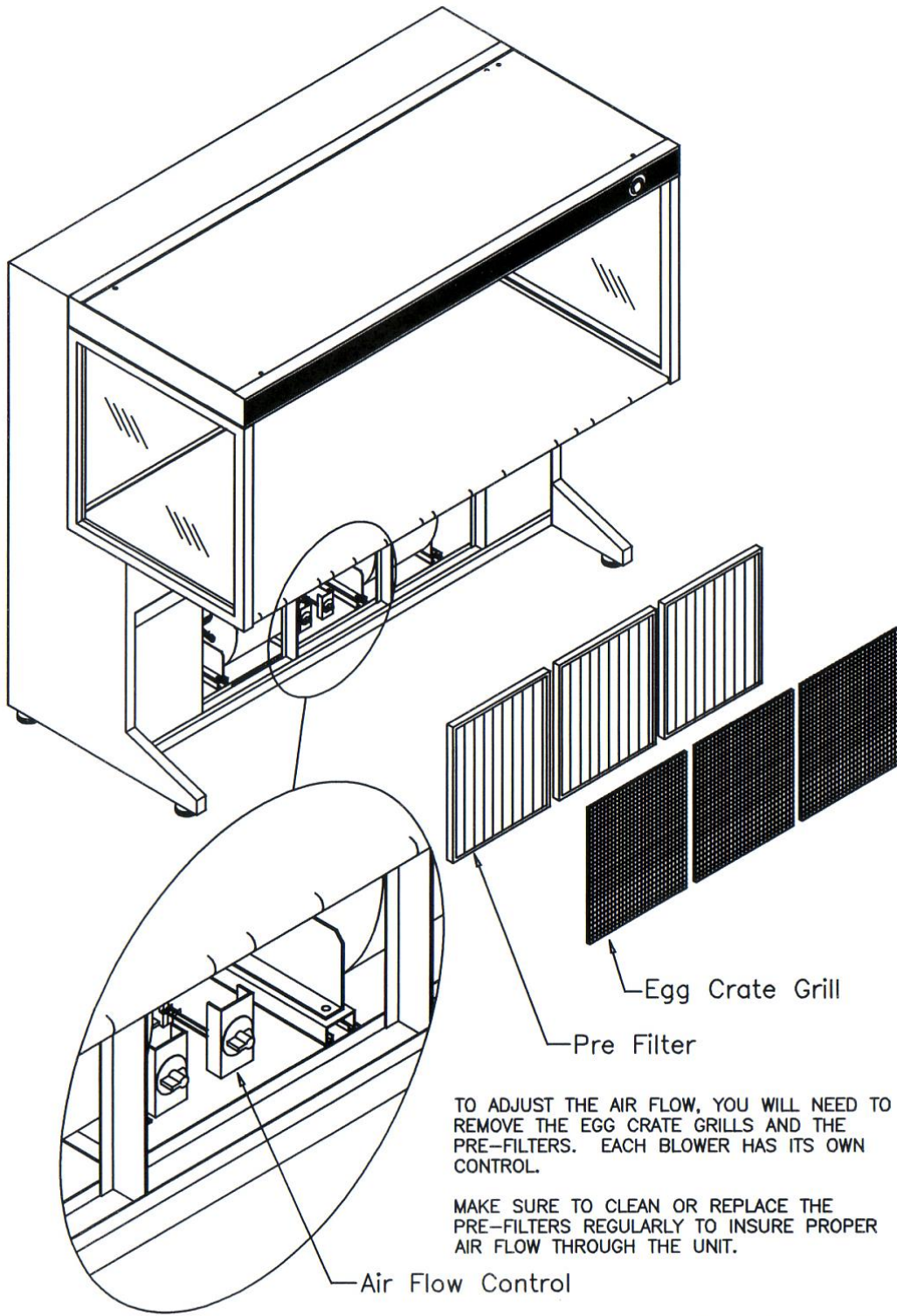

## Filter Maintenance & Replacement:

### HEPA Filter:

The HEPA filter in this unit has protective screens across its face and in the back. IAC AirClean units are equipped with a magnehelic gage which measures the air pressure in the blower housing. This information is used to help determine when the HEPA filter needs to be replaced. This gage will read higher as the HEPA filter loads up with particles. When it read 2.0 WG it is a good indication that the HEPA filter may need to be replaced. However as long as the airflow volume is sufficient the HEPA filter does not need to be replaced.

As the filter loads up with particles you will use the motor speed controls to increase the air flow as instructed on page 8 & 9. When the speed controls are at 100% and the unit cannot maintain the recommended airflow volume it is time to replace the HEPA filter. Replacement filters are available from IAC Industries or any HEPA filter manufacturer.

### HEPA Filter Replacement:

Qualified maintenance personnel training in such activities should do HEPA filter replacement. The unit must be **TURNED OFF AND DICONNECTED FOR IT'S POWER SOURCE** and remain off during the HEPA filter replacement procedure. Installing the replacement HEPA filter correctly is critical to the efficient operation of the unit.

Note: it is critical that great care is taken when handling replacement HEPA filters. IAC recommends that at least three individuals be used to remove and replace the HEPA filter.

- 1) Remove the back panel by removing the screws holding the back panel to the upper housing. This will require that at least three personnel be used.
- 2) Remove the HEPA filter retainer brackets by removing the bolts. Do this in a sequence that allows the HEPA filter to be supported until all the retainer brackets are removed and the filter can be pulled out.
- 3) Carefully remove the HEPA filter by carefully pulling the filter to clear the upper housing walls. Then remove the filter.
- 4) Install the new HEPA filter making sure the foam insulation around the filter is facing towards the inside of the upper housing. Push the filter firmly against the unit's upper housing grille.
- 5) Install the HEPA filter clamps and bolts.

The unit is now ready to be re-certified by a qualified clean room certification firm or by the customer's trained personnel. See pages 7, 8&9 for instructions.

### **Pre-filter Replacement:**

Pre-filters can last as long as a full year depending on the environment the unit is in. Normally pre-filters are changed every 3 to 6 months. Not replacing the pre-filters on a regular basis will reduce the airflow volume and thus affect the efficiency of your AirClean unit. Pre-filters are located below the worksurface behind the egg crate diffusers on the AirClean unit.

**BEFORE** replacing pre-filters turn the unit's impellers off and allow them time to spin down and stop. Then remove the egg crate diffusers and the pre-filters and replace with new pre-filters and replace the egg crate diffusers then turn the unit's motor on.

### **Light Tubes:**

Light tubes are not included with the AirClean unit. IAC recommended light tubes are F(xx) T12. The "xx" refers to the nominal length of the light tubes which must correspond to the nominal length of the HFS AirClean unit.

### **Airflow Volume Calibration:**

To calibrate the airflow of the AirClean unit see page 8&9.

### **Particle Count Certification:**

Particle count certification should be conducted per each company's Cleanroom Policies and Procedures and by qualified calibration personnel.

### **General Information:**

It should be recognized that although the airflow inside an AirClean unit work area is clean the air circulating outside the work area can be contaminated at various degrees. Care must be taken to prevent that this contamination is not introduced into the work area by operator's movements, items being carried into the work area, and/or equipment and tools placed in and around the work area. Particles generated in the vicinity of the work area may penetrate the air stream by following the operator's movements of arms and hands from outside the work area into the work area.

It should be noted that the more contaminated the air surrounding the AirClean unit is the faster the pre-filters and HEPA filters will load up with particles. This will increase the number of times these filters will need to be changed.

## **Standard Operating Conditions:**

- A. After an AirClean unit has been put into service it should not be shut down under normal circumstances. Shutting down an AirClean unit allows particles to enter and settle into the work area.
- B. If it is necessary to shut the AirClean unit down, an evaluation should be made whether contaminants have accumulated into the work area or filter grille. The work area should be cleaned with a DAMP lint free cloth.
- C. When the unit has been cleaned it should be run for at least 30 minutes before starting any work operations. It may be the unit's owner company cleanroom policy that any unit shut down must be recalibrated before it can be placed back in service. Review these requirements before beginning any work in the unit.
- D. After the unit has run for at least 10 minutes the work area should again be wiped down with a DAMP lint free cloth isopropyl alcohol filtered to 0.5 microns.
- E. The work area should also be wiped down at least once per 8-hour shift. More frequent cleaning may be required.

## **Workplace and Equipment Controls:**

- A. All materials such as work pieces, tools, containers, etc. should be free of particulate matter before being placed into the work area. DO NOT store items that can emit particles on shelves above the pre-filters, as this will increase the number of time the pre-filters will need to be changed.
- B. Do not position objects between the work piece and the HEPA filter. This can restrict the airflow causing turbulence and eddies where particles can accumulate.
- C. Only items that are cleanroom approved should be placed in the unit's work area.
- D. Objects must not be stored on top of the AirClean unit housing