

## DIMENSION 4 **Mobile Accessory Station MAS**

REV. 042318

### **IAC INDUSTRIES**

3831 S BULLARD AVE., GOODYEAR, AZ 85338  
Phone (714) 990-8997 Fax (714) 990-0557

[www.iacindustries.com](http://www.iacindustries.com)

## **D4** Mobile Accessory Station **Assembly Instructions**

## DIMENSION 4 Mobile Accessory Station MAS ASSEMBLY INSTRUCTIONS

Page #

3

Attention Notes

4 - 9

D4 Mobile Accessory Station

### Cautionary Notes and Warnings:



IAC strongly recommends care must be taken during the lifting and positioning of all workstation components as they can be heavy and awkward to lift, move and install. Only qualified installation personnel using the proper Personal Protective Equipment should be allowed to lift any of these components into place. Failure to use proper lifting techniques and proper Personal Protective Equipment could result in injury individuals, the workstation and/or surrounding property. IAC Industries is not responsible for any injuries sustained or damage to the workstation and its contents and/or damage to surrounding property caused during the proper or improper installation of the workstation.

**Note:** For Basic Assembly Instructions to the D4 accessories please use the D4 Assembly Instructions included with your shipment. Before starting the assembly of the D4 Mobile Accessory Station. After assembly is complete test the movement of all accessories to be sure the outlets, power cords and interconnects will not be damaged by any accessory location.

# Table Of Contents

Page #	
2	Pre-assembly Check List
3	D4 Mobile Accessory Station

## ATTENTION NOTES:

Congratulations on your purchase of the Dimension 4 Mobile Accessory Station. Please read through all the assembly instruction pages before you begin assembling your work station.

IAC Industries takes great care in the packing of its products, however damage can occur during shipment. Check all packages and parts for any signs of damage. If damage is evident STOP and contact the carrier that delivered your order. Request a freight claim inspector to document the damage and begin the freight claim process.

Tools required to assemble your products are:

7/16" and 1/2" wrench or socket with ratchet. Phillips screwdriver 8" long.  
Utility knife. Safety glasses and light duty protective gloves.

Power tools are not recommended unless they are equipped with a torque-limiting device which can limit the torque to 10-foot lbs maximum.

Unpack your order and separate like parts. Be careful not to damage parts as they are being moved into position. Also be sure all parts are removed from the packing materials before these materials are thrown away.

Locate the hardware kits and keep them in a central area. If the assembly is going to take more than one day, all individual hardware pieces should be returned to a central location.

Check all parts and hardware kits against the itemized packing list found with the assembly instructions. If you believe there are parts missing from your order please contact IAC Industries customer service at 800-989-1422.

**WHILE THIS PRODUCT IS DESIGNED WITH SAFETY IN MIND, IMPROPER USE CAN RESULT IN INJURY TO THE OPERATOR AND DAMAGE TO THE PRODUCT. OPERATORS MUST BE FULLY TRAINED IN THE PROPER USE OF THIS WORKSTATION. FOR TRAINING ASSISTANCE PLEASE CONTACT YOUR LOCAL REPRESENTATIVE, THE COMPANY YOU PURCHASED THE PRODUCT FROM OR THE IAC INDUSTRIES FACTORY.**

## D4 Mobile Accessory Station

ITEM	DESCRIPTION	QTY
1	D4 Back Panel	1
2	D4 Top Support Bracket LT	1
3	D4 Top Support Bracket RT	1

### HARDWARE KIT HWR214

ITEM	DESCRIPTION	QTY
A	Bolt 5/16-18 x .75 SQH	8
B	Washer 5/16 Flat	8
C	Nut 5/16-18 Hex Keps	8



Please read Caution and Warning Notices found on page 2.

### Step 1:

Install 5/16-18 x .75 square head bolts item A, 5/16 flat washer item B, and 5/16-18 hex head keps nuts item C into each end of all back panel item 1 as shown below. Do not tighten this hardware.

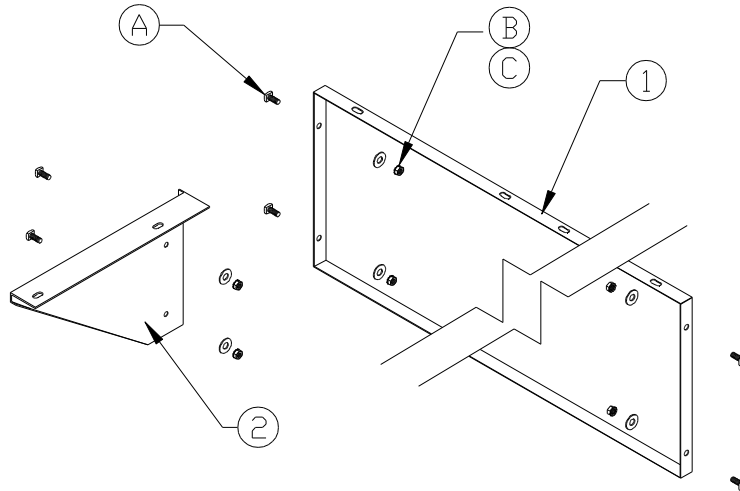

### Step 2:

Make small pencil marks on the MAS uprights approximately **1 1/4"** lower than the desired working height. It is a good idea to make these marks all the uprights at the same time. Install the back panel by leaning an upright against a wall or have a second person hold it and install the square head bolts into the milled slots in the nut channels of the MAS upright. Gently slide the back panel to the pencil marks and tighten the hex head keps nuts to hold them in place. Do not tighten this hardware to more than 10 foot lbs of torque. Doing so will cause scoring to the aluminum of the upright.

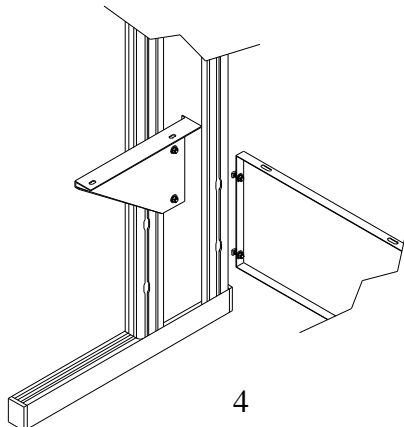

**Step 3:**

Attach the back panel to the second MAS upright by having one person hold the back panel in place while another person lifts the other MAS upright so that the square head bolts can be installed into the milled slots in the upright nut channel and gently sliding the upright down to the floor. Gently slide the back panel to the pencil marks on the upright and tighten the hex head keps nuts to hold it in place. Do not tighten this hardware to more than 10 foot lbs. of torque.

**Figure 1**

